

650V N-Channel Enhancement Mode Power MOSFET

MAIN CHARACTERISTICS

I_D	16A
V_{DSS}	650V
R_{DS(on)-typ(@V_{GS}=10V)}	<0.55Ω(Typ:0.43Ω)

FEATURES

- ◆Fast Switching
- ◆Low ON Resistance
- ◆Low Gate Charge
- ◆100% Single Pulse avalanche energy Test

APPLICATIONS

- ◆Power switch circuit of adaptor and charger.
- ◆SMPS Power Supply
- ◆LCD Panel Power

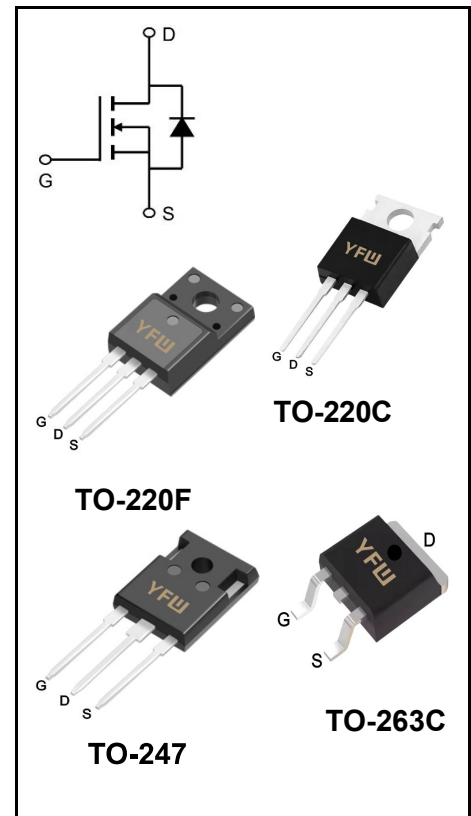

Maximum Ratings at T_c=25°C unless otherwise specified

Characteristics	Symbols	Value		Units
		TO-220F	TO-247/TO-220C/TO-263C	
Drain-Source Voltage	V_{DS}	650		V
Gate - Source Voltage	V_{GS}	±30		V
Continuous drain current	I_D	16		A
Pulsed Drain Current (Note1)	I_{DM}	64		A
Power dissipation	P_D	44	160	W
Single Pulse Avalanche Energy(Note1)	E_{AS}	1100		mJ
Operating Temperature Range	T_J	150		°C
Storage Temperature Range	T_{STG}	-55 to +150		°C
Thermal Resistance, Junction-case	R_{θJC}	2.85	0.78	°C/W
Thermal Resistance, Junction to Ambient	R_{θJA}	110	62	°C/W

Note1:Pulse test: 300 μs pulse width, 2 % duty cycle

Maximum Ratings at Tc=25°C unless otherwise specified

Characteristics	Test Condition	Symbols	Min	Typ	Max	Units
Drain-Source Breakdown Voltage	$V_{GS}=0V, I_D=250\mu A$	BV_{DSS}	650	-	-	V
Drain-Source Leakage Current	$V_{DS}=650V, V_{GS}=0V$	I_{DSS}	-	-	1	μA
Gate-Source Leakage Current	$V_{DS} = \pm 30V, V_{GS} = 0V$	I_{GSS}	-	-	± 100	nA
Gate -Threshold Voltage	$V_{DS}=V_{GS}, I_D=250\mu A$	$V_{GS(th)}$	2	-	4	V
Drain-Source On-State Resistance	$V_{GS} = 10V, I_D = 8A$	$R_{DS(ON)}$	-	0.43	0.55	Ω
Forward Transconductance	$V_{GS}=15V, I_D=8A$	g_{fs}	-	15	--	S
Input Capacitance	$V_{GS}=0V$ $V_{DS}=25V$ $f = 1000KHz$	C_{iss}	-	2400	-	pF
Output Capacitance		C_{oss}	-	225	-	
Reverse Transfer Capacitance		C_{rss}	-	105	-	
Turn-on delay time	$I_D = 16A$ $V_{DD} = 325V$ $R_G = 25\Omega$	$t_{d(on)}$	-	35	-	ns
Rise Time		T_r	-	42	-	
Turn-Off Delay Time		$t_{d(OFF)}$	-	88	-	
Fall Time		t_f	-	43	-	
Total Gate Charge	$I_D = 16A$ $V_{DD} = 250V$ $V_{GS} = 10V$	Q_g	-	65	-	nC
Gate-Source Charge		Q_{gs}	-	11	-	
Gate-Drain Charge		Q_{gd}	-	26	-	
Diode forward current		I_S	-	-	16	A
Maximun Body-Diode Pulsed Current(Note2)		I_{SM}	-	-	64	A
Diode Forward Voltage	$I_S=16A$	V_{SD}	-	-	1.5	V
Reverse Recovery Time(Note2)		trr	-	555	-	ns
Reverse Recovery Charge(Note2)	$I_{SD} = 16A, V_{GS} = 0V,$ $dI_f / dt = 100A/\mu s$	Q_{rr}	-	4.2	-	μC

Note2:Pulse test: 300 μs pulse width, 2 % duty cycle

Ratings and Characteristic Curves

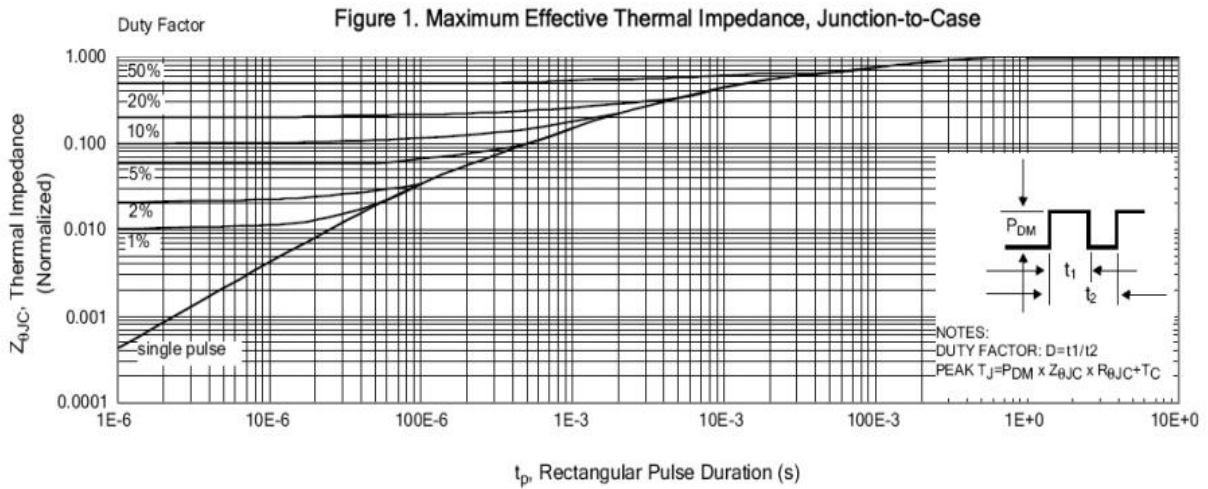

Figure 2. Maximum Power Dissipation vs Case Temperature

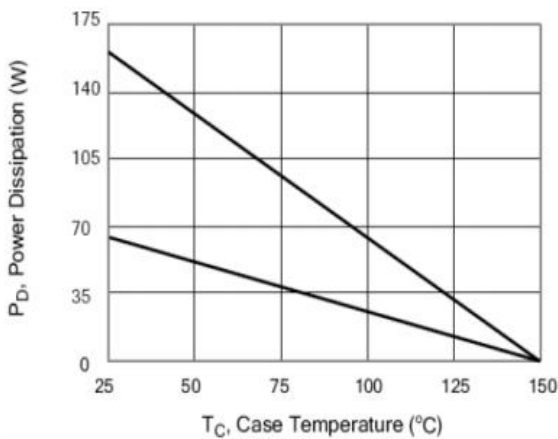

Figure 3. Maximum Continuous Drain Current vs Case Temperature

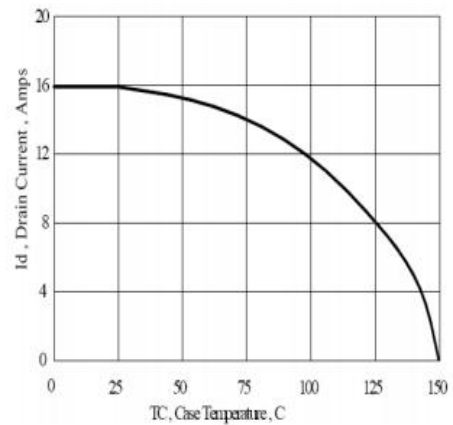

Figure 4. Typical Output Characteristics

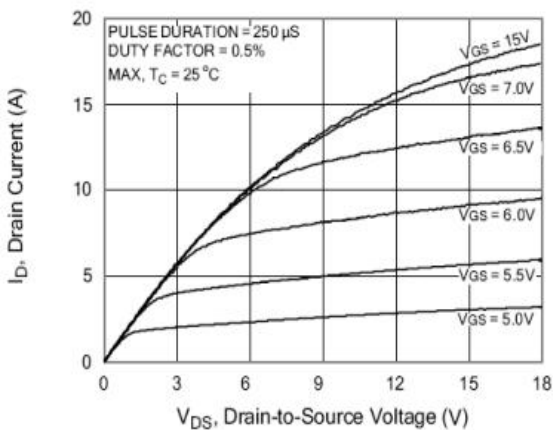
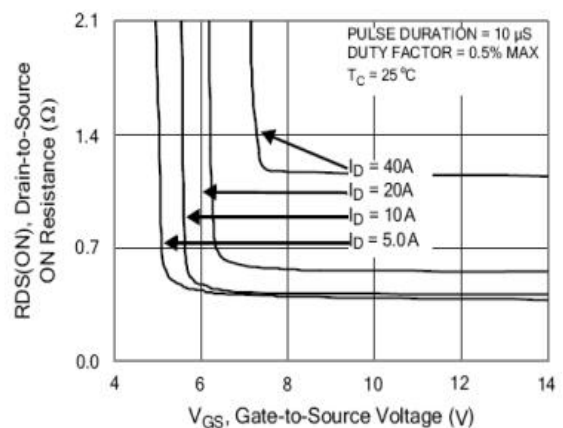

Figure 5. Typical Drain-to-Source ON Resistance vs Gate Voltage and Drain Current



Ratings and Characteristic Curves

Figure 6. Maximum Peak Current Capability

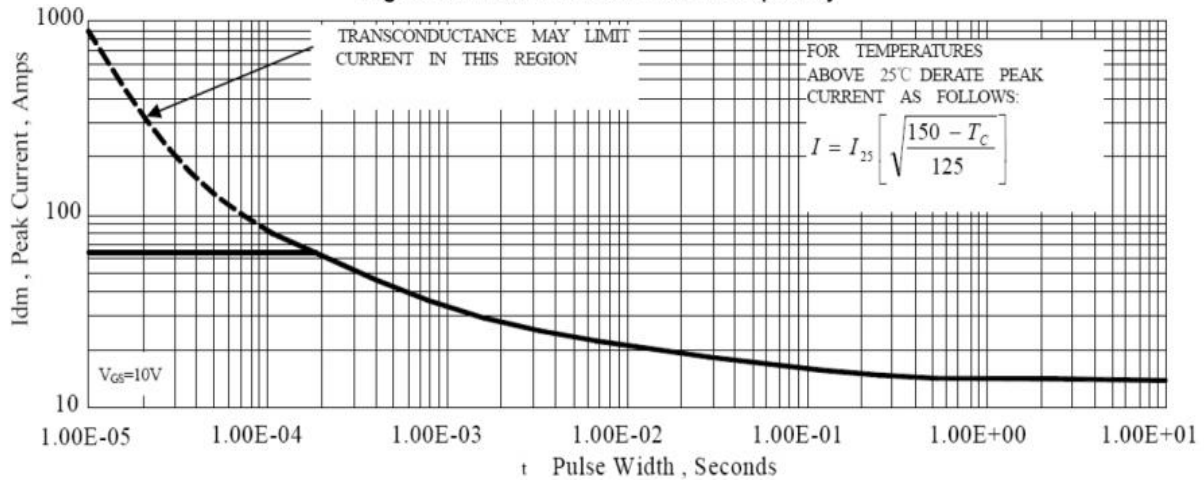

Figure 7. Typical Transfer Characteristics

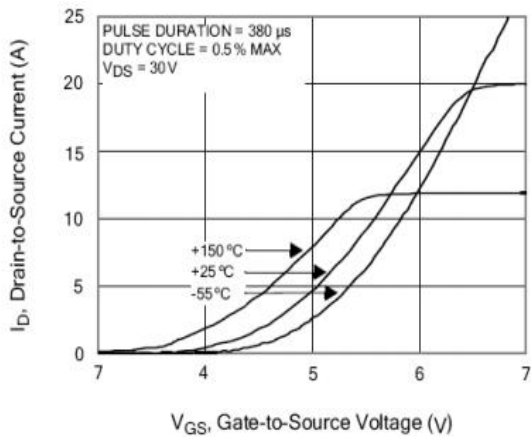

Figure 9. Typical Drain-to-Source ON Resistance vs Drain Current

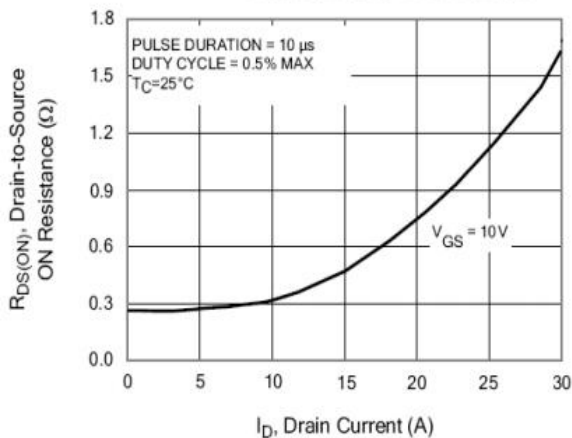

Figure 8. Unclamped Inductive Switching Capability

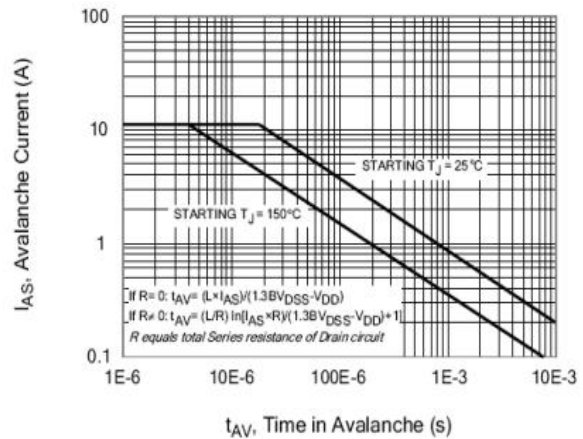
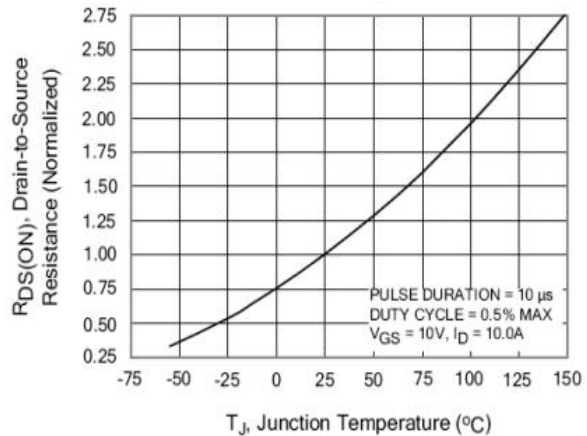

Figure 10. Typical Drain-to-Source ON Resistance vs Junction Temperature



Ratings and Characteristic Curves

Figure 11. Typical Breakdown Voltage vs Junction Temperature

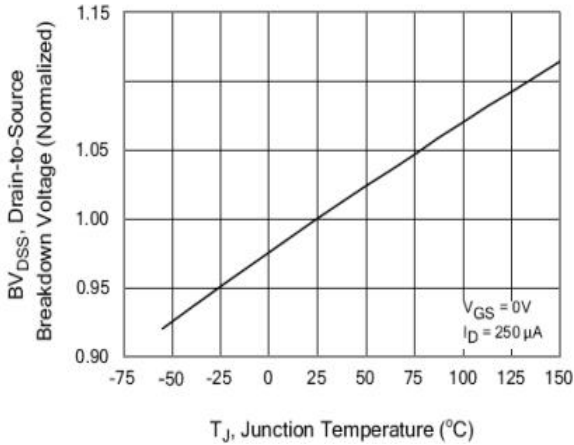

Figure 12. Typical Threshold Voltage vs Junction Temperature

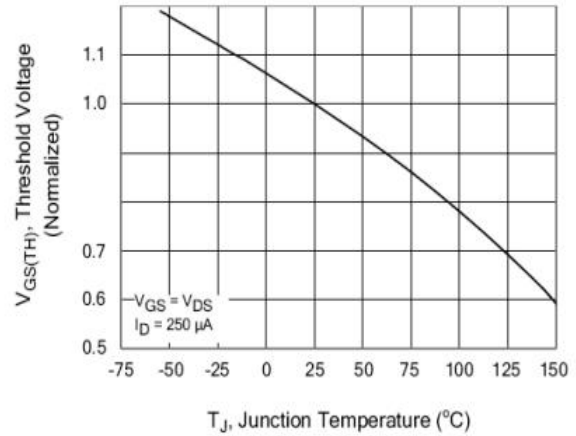

Figure 13. Maximum Forward Bias Safe Operating Area

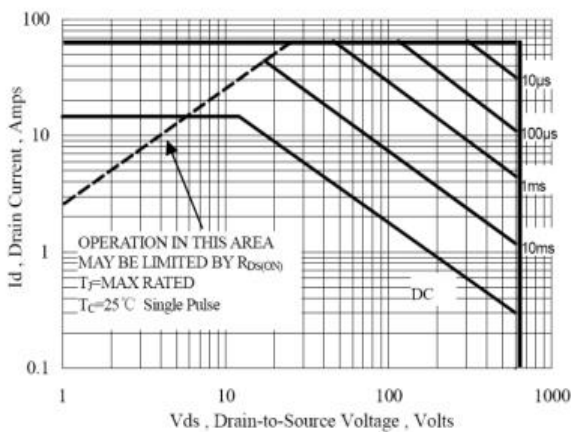

Figure 14. Typical Capacitance vs Drain-to-Source Voltage

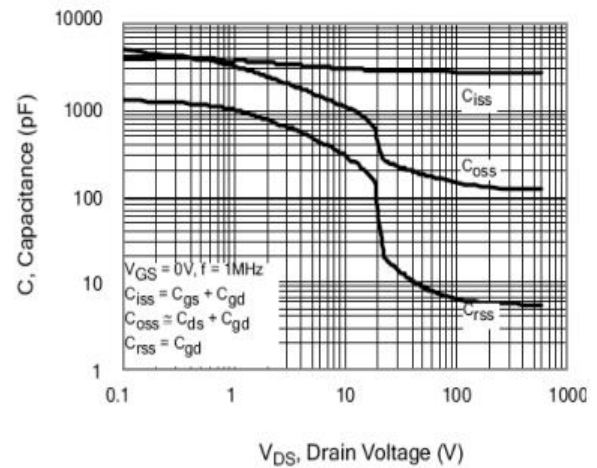

Figure 15. Typical Gate Charge

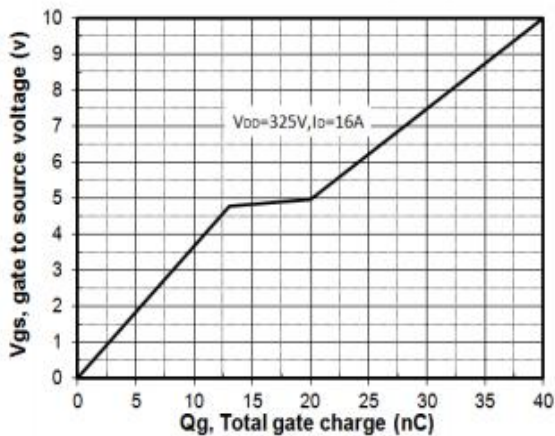
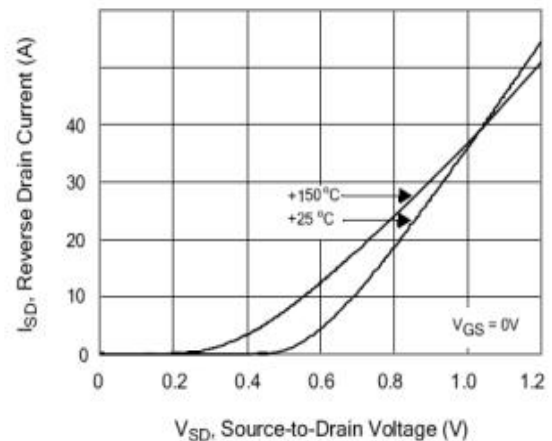
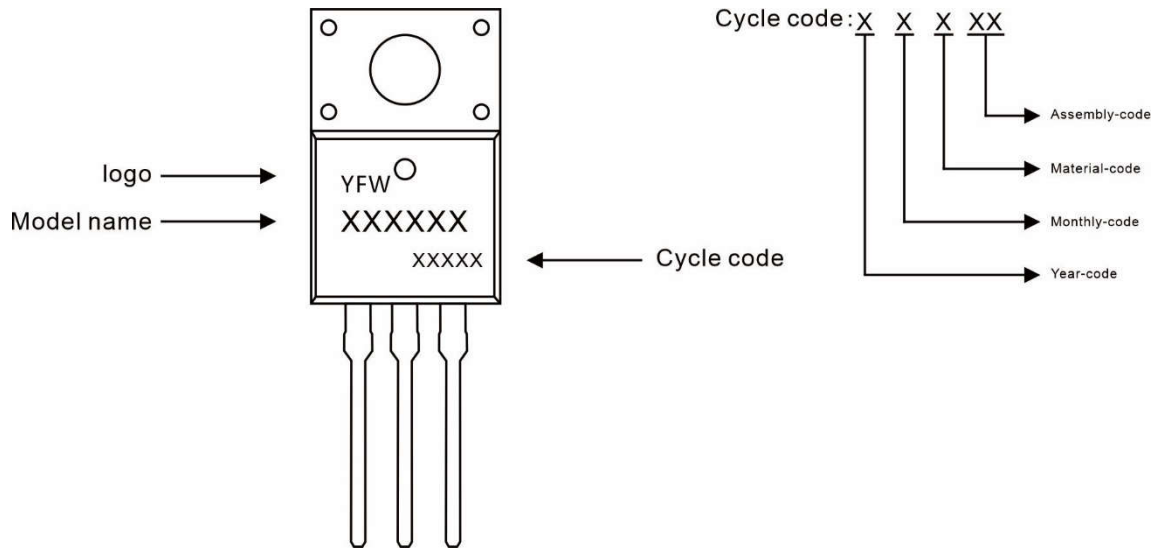

Figure 16. Typical Body Diode Transfer Characteristics



Marking Diagram



Ordering information

Model name	Package	Unit Weight	Base Quantity	Packing Quantity
YFW16N65AF	TO-220F	0.06oz(1.74g)	50pcs/tube	1000PCS/Box 5000PCS/Carton

Package Dimensions

TO-220F

Symbol	Millimeter		Inches	
	Min.	Max.	Min.	Max.
A	4.50	4.90	0.177	0.193
A1	2.34	2.74	0.092	0.108
A2	2.66	2.86	0.105	0.113
b	0.75	0.85	0.030	0.033
b1	1.24	1.44	0.049	0.057
c	0.40	0.60	0.016	0.024
D	10.00	10.32	0.394	0.406
E	15.75	16.05	0.620	0.632
e	2.44	2.64	0.096	0.104
e1	4.88	5.28	0.192	0.208
F	3.10	3.5	0.122	0.138
L	13.50	13.90	0.531	0.547
L1	2.90	3.30	0.114	0.130
Φ	3.10	3.30	0.122	0.130

Marking Diagram

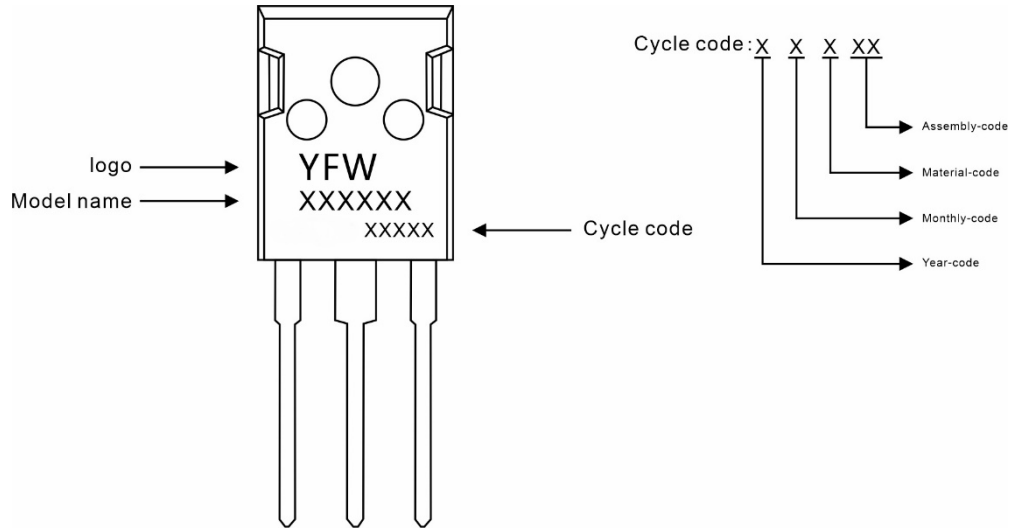

Ordering information

Model name	Package	Unit Weight	Base Quantity	Packing Quantity
YFW16N65AP	TO-247	0.209oz(5.93g)	30pcs/tube	600PCS/Box 2400PCS/Carton

Package Dimensions

TO-247

Symbol	Dimensions in mm		Dimensions in Inch	
	Min.	Max.	Min.	Max.
A	4.90	5.10	0.193	0.201
A1	1.90	2.10	0.075	0.083
A2	2.29	2.54	0.090	0.100
b	1.00	1.40	0.039	0.055
b1	2.00	2.20	0.079	0.087
b2	3.00	3.20	0.118	0.126
c	0.50	0.70	0.020	0.028
D	15.75	16.05	0.620	0.632
E	20.20	20.80	0.795	0.819
e	5.45 (BSC)		0.215 (BSC)	
e1	10.90 (BSC)		0.429 (BSC)	
F	6.05	6.25	0.238	0.246
F1	5.80	6.00	0.228	0.236
L	20.10	20.40	0.791	0.803
L1	4.05	4.35	0.159	0.171
Φ	3.50	3.70	0.138	0.146

Marking Diagram

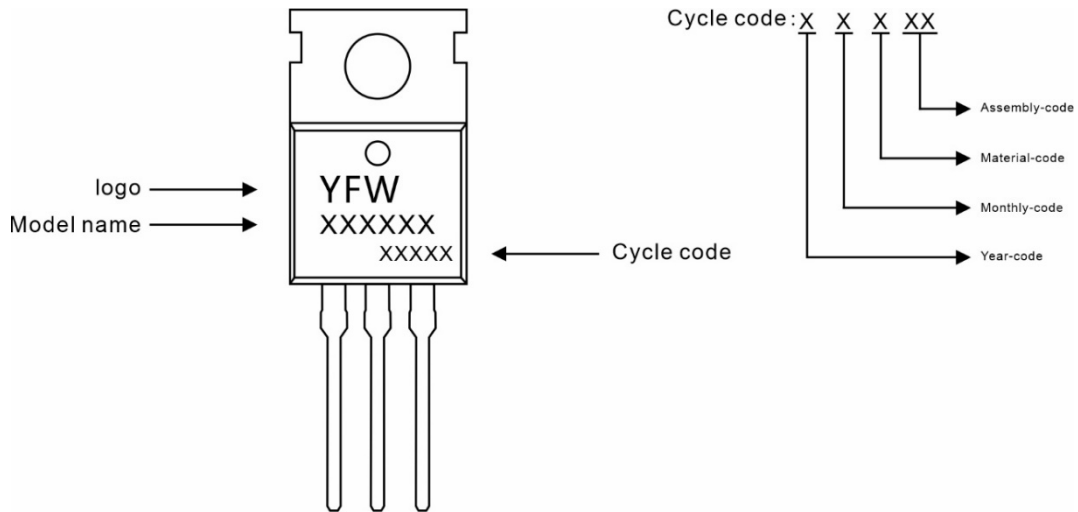

Ordering information

Model name	Package	Unit Weight	Base Quantity	Packing Quantity
YFW16N65AC	TO-220C	0.07oz(1.96g)	50pcs/tube	1000PCS/Box 5000PCS/Carton

Package Dimensions

TO-220C

Dim	Millimeter		Inches	
	Min.	Max.	Min.	Max.
A	4.34	4.67	0.171	0.184
A1	2.52	2.82	0.099	0.111
b	0.71	0.91	0.028	0.036
b1	1.17	1.37	0.046	0.054
c	0.30	0.50	0.012	0.020
c1	1.17	1.37	0.046	0.054
D	9.90	10.20	0.390	0.402
E	8.50	8.90	0.335	0.350
E1	12.00	12.50	0.472	0.492
e	2.44	2.64	0.096	0.104
e1	4.88	5.28	0.192	0.208
F	2.60	2.80	0.102	0.110
L	13.20	13.80	0.520	0.543
L1	3.80	4.20	0.150	0.165
Φ	3.60	3.96	0.142	0.156

Marking Diagram

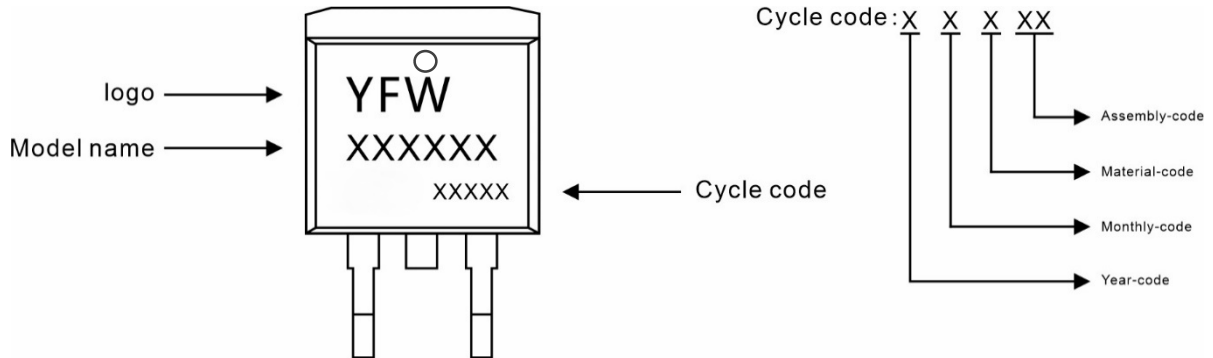

Ordering information

Model name	Package	Unit Weight	Base Quantity	Packing Quantity
YFW16N65ASC	TO-263C	0.04oz(1.16g)	800pcs/reel	1600pcs/box 8000pcs/Carton

Package Dimensions

TO-263C

Dim	Millimeter		Inches	
	Min.	Max.	Min.	Max.
A	4.30	4.70	0.169	0.185
A1	0.00	0.15	0.000	0.006
A2	4.30	4.55	0.169	0.179
B	1.10	1.50	0.043	0.059
b	0.70	0.90	0.028	0.035
b1	1.20	1.50	0.047	0.059
c	0.30	0.60	0.012	0.024
c1	1.17	1.37	0.046	0.054
D	9.90	10.20	0.390	0.402
E	8.50	8.90	0.335	0.350
e	2.44	2.64	0.096	0.104
e1	4.88	5.28	0.192	0.208
L	15.00	15.30	0.591	0.602
L1	5.20	5.40	0.205	0.213
L2	2.40	2.60	0.094	0.102
L3	1.60	1.80	0.063	0.071

Disclaimer

The information presented in this document is for reference only. GuangDong Youfeng Microelectronics Co.,Ltd. reserves the right to make changes without notice for the specification of the products displayed herein to improve reliability, function or design or otherwise. The product listed herein is designed to be used with ordinary electronic equipment or devices, and not designed to be used with equipment or devices which require high level of reliability and the malfunction of which would directly endanger human life (such as medical instruments, transportation equipment, aerospace machinery, nuclear-reactor controllers, fuel controllers and other safety devices), YFW or anyone on its behalf, assumes no responsibility or liability for any damages resulting from such improper use of sale. This publication supersedes & replaces all information previously supplied. For additional information, please visit our website <https://www.yfwdiode.com>, or consult YFW sales office for further assistance.