

12A 4Quadrants TRIAC

Product Summary

Symbol	Value	Unit
IT(RMS)	12	A
V _{DRM} V _{R_{RM}}	600/800	V
V _{TM}	1.55	V

FEATURES

- ◆ Silicon bidirectional device with NPNPN five-layer structure
- ◆ P-type interdiffusion isolation structure
- ◆ Mesa glass passivation process
- ◆ High operating junction temperature
- ◆ Excellent commutation capability
- ◆ High dV/dt immunity
- ◆ High dI/dt immunity
- ◆ RoHS compliance

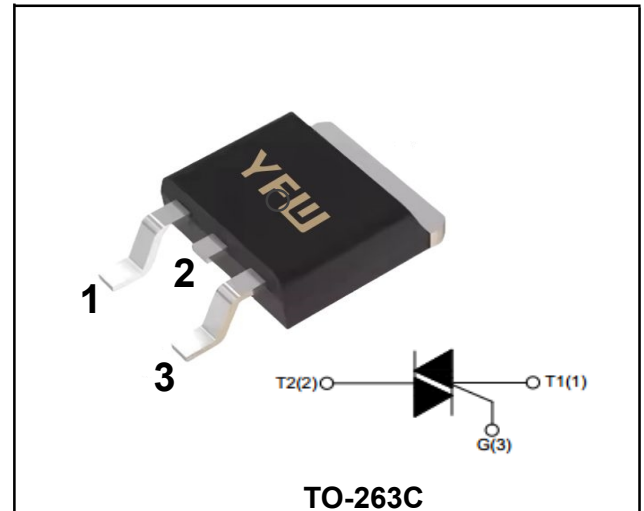

APPLICATIONS

- ◆ Heating controllers; speed controllers
- ◆ Household appliances including washing machines, mixers, coffee makers, power tools, vacuum cleaners, etc.

Absolute maximum ratings (Ta=25°C unless otherwise noted)

Parameter	Symbol	Value	Unit	
Repetitive peak off-state voltage	V _{DRM}	600/800	V	
Repetitive peak reverse voltage	V _{R_{RM}}	600/800	V	
RMS on-state current	IT(RMS)	12	A	
Non repetitive surge peak on-state current (full cycle, F=50Hz)	I _{TSM}	95	A	
I ² t value for fusing (tp=10ms)	I ² t	45	A ² s	
Critical rate of rise of on-state current (IG =2 x GT)	dI/dt	I-II-III	50	A/μs
		IV	10	
Peak gate current	I _{GM}	2	A	
Gate peak power	I _{GM}	5	W	
Average gate power dissipation	P _{G(AV)}	0.5	W	
Junction Temperature	T _J	-40~+125	°C	
Storage Temperature	T _{STG}	-40 ~+150	°C	

Electrical characteristics (TA=25°C, unless otherwise noted)

Parameter	Symbol	Test Condition	Value			Unit	
			D	E	F		
Gate trigger current	I_{GT}	$V_D=12V$, $I_T=0.1A$, $T_j=25^\circ C$, Fig.6	I - II - III	≤ 5	≤ 10	≤ 25	mA
			IV	≤ 10	≤ 25	≤ 70	
Gate trigger voltage	V_{GT}	I - II - III - IV	≤ 1.3			V	
Gate non-trigger voltage	V_{GD}	$V_D=V_{DRM}$, $T_j=125^\circ C$	≥ 0.2			V	
Holding current	I_H	$V_D = 12V$, $I_{GT}=0.1A$, $T_j=25^\circ C$, Fig.6	I - II - III - IV	≤ 10	≤ 30	≤ 30	mA
latching current	I_L		I - III - IV	≤ 15	≤ 30	≤ 40	mA
			II	≤ 20	≤ 40	≤ 60	mA
Critical-rate of rise of commutation voltage	dV_D/dt	$V_D=67\%_{DRM}$, $T_j=125^\circ C$	≥ 10	≥ 20	≥ 50	V/us	

STATIC CHARACTERISTICS

Forward "on" voltage	V_{TM}	$I_{TM}=15A$, $t_p=380us$, Fig.4	≤ 1.55			V	
Repetitive Peak Off-State Current	I_{DRM}	$V_D=V_{DRM}$ $V_R=V_{RRM}$	$T_j=25^\circ C$	≤ 10	≤ 10	≤ 10	uA
Repetitive Peak Reverse Current	I_{RRM}		$T_j=125^\circ C$	≤ 1	≤ 1	≤ 1	mA

THERMAL RESISTANCES

Thermal resistance	$R_{th(j-c)}$	Junction to case(AC)	TYP.	1.4	°C/W
	$R_{th(j-a)}$	Junction to ambient $S=1\text{ cm}^2$	TYP.	45	°C/W

Ordering Information

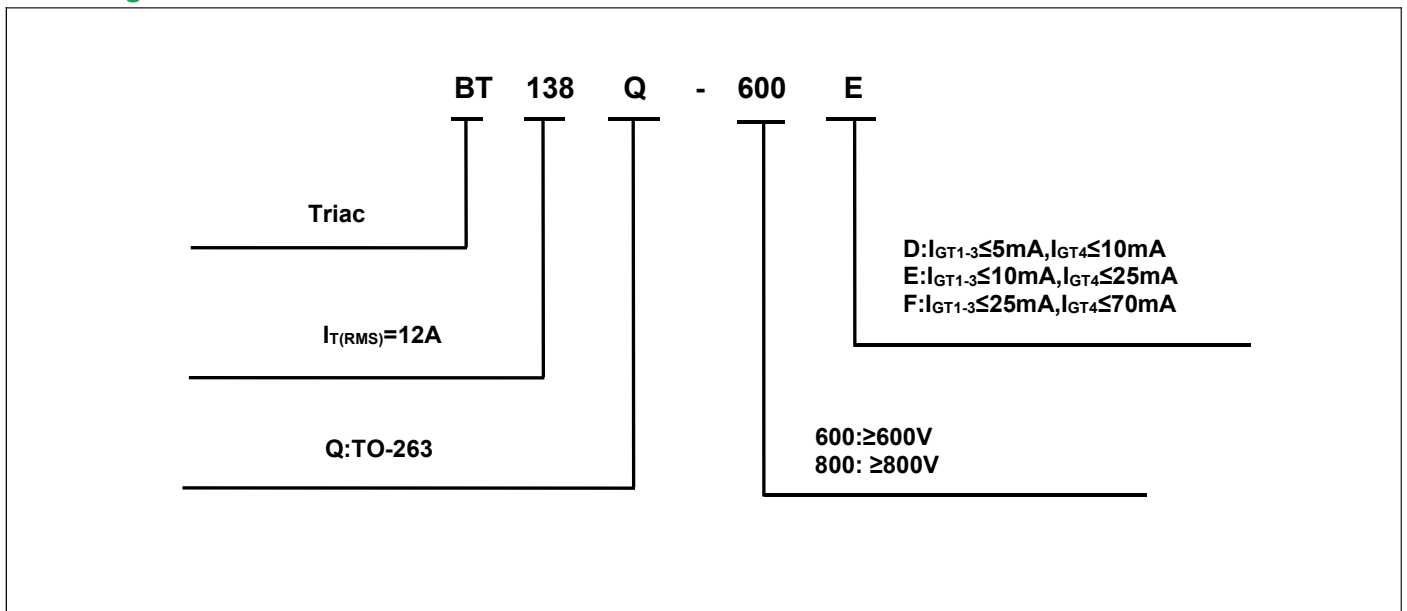

Typical Characteristics

FIG.1 Max. Power vs RMS Current Curve

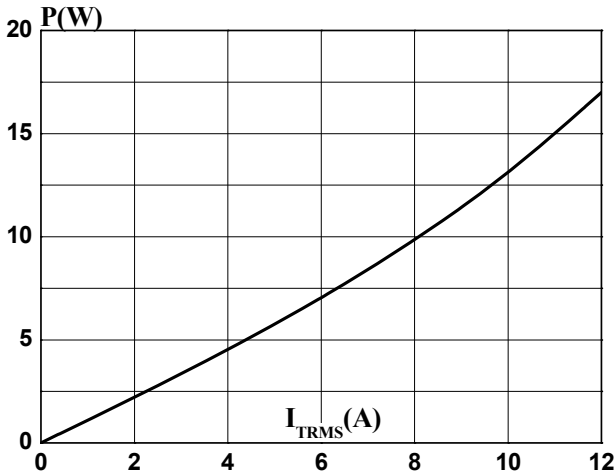

FIG.2: RMS Current vs Case Temperature Characteristic Curve

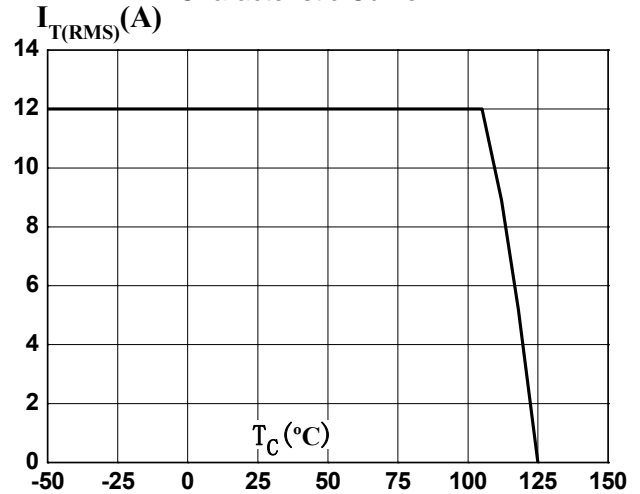

FIG.3: Peak Surge Current vs Number of Cycles Graph

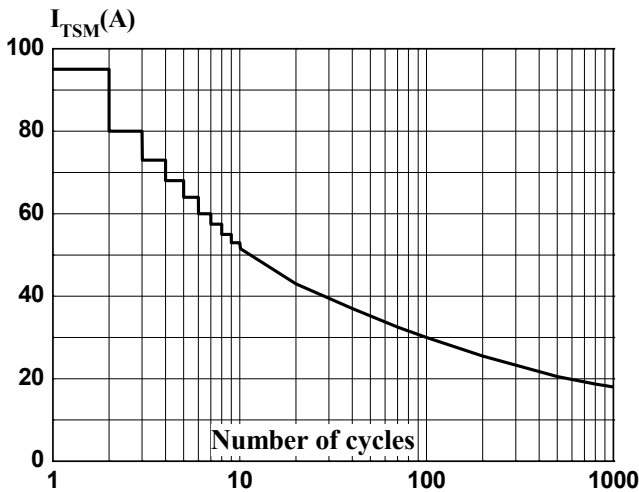

FIG.4: Output Characteristic Graph (Maximum Value Graph)

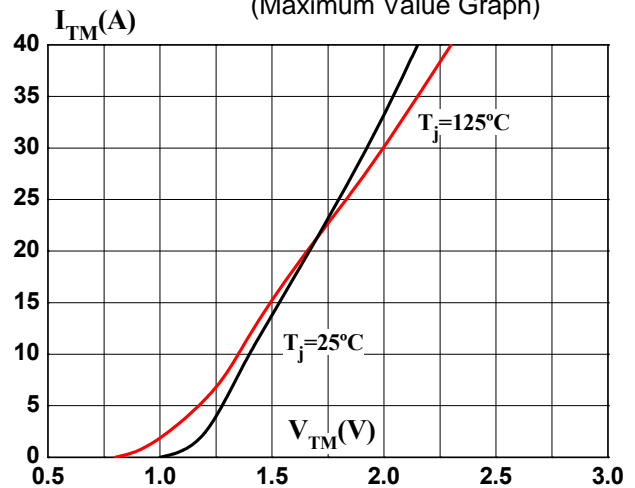

FIG.5: Non-repetitive Peak Surge Current vs Sine Wave Pulse Width Characteristic Curve

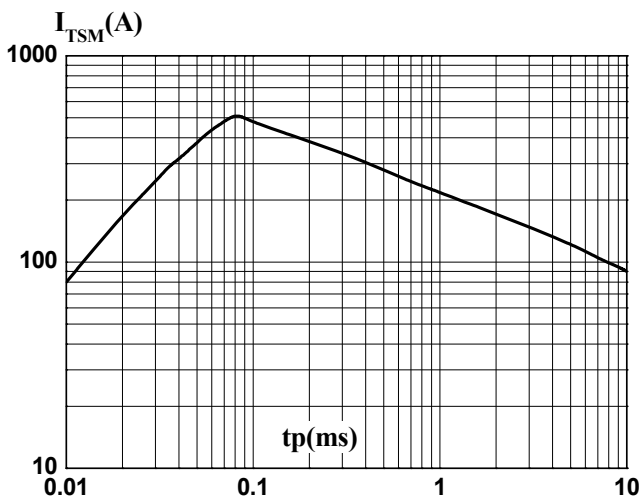
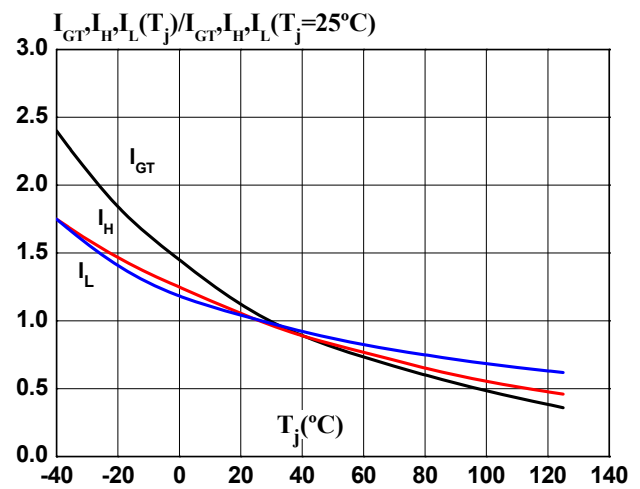
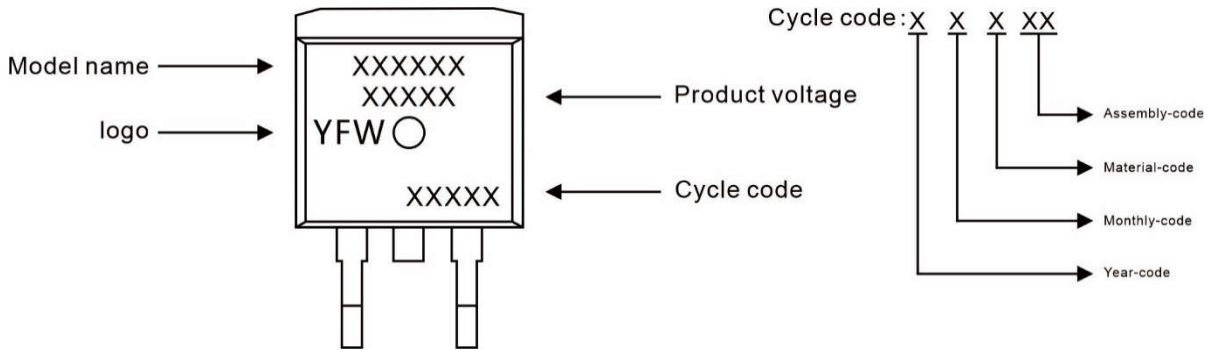

FIG.6: Gate Trigger Current, Holding Current, Latching Current vs Junction Temperature Curve



Marking Diagram



Ordering information

Model name	Package	Unit Weight	Base Quantity	Packing Quantity
BT138Q	TO-263C	0.04oz(1.16g)	800pcs/reel	1600pcs/box 8000pcs/Carton

Package Dimensions

TO-263C

Dim	Millimeter		Inches	
	Min.	Max.	Min.	Max.
A	4.30	4.70	0.169	0.185
A1	0.00	0.15	0.000	0.006
A2	4.30	4.55	0.169	0.179
B	1.10	1.50	0.043	0.059
b	0.70	0.90	0.028	0.035
b1	1.20	1.50	0.047	0.059
c	0.30	0.60	0.012	0.024
c1	1.17	1.37	0.046	0.054
D	9.90	10.40	0.390	0.409
E	8.50	8.90	0.335	0.350
e	2.44	2.64	0.096	0.104
e1	4.88	5.28	0.192	0.208
L	15.00	15.30	0.591	0.602
L1	5.20	5.40	0.205	0.213
L2	2.40	2.60	0.094	0.102
L3	1.60	1.80	0.063	0.071

Disclaimer

The information presented in this document is for reference only. GuangDong Youfeng Microelectronics Co.,Ltd. reserves the right to make changes without notice for the specification of the products displayed herein to improve reliability, function or design or otherwise. The product listed herein is designed to be used with ordinary electronic equipment or devices, and not designed to be used with equipment or devices which require high level of reliability and the malfunction of with would directly endanger human life (such as medical instruments, transportation equipment, aerospace machinery, nuclear-reactor controllers, fuel controllers and other safety devices),YFW or anyone on its behalf, assumes no responsibility or liability for any damages resulting from such improper use of sale. This publication supersedes & replaces all information previously supplied. For additional information, please visit our website <https://www.yfwdiode.com>, or consult YFW sales office for further assistance.