

**800V SiC N-Channel MOSFET**

**MAIN CHARACTERISTICS**

|   |                 |
|---|-----------------|
| <b>I<sub>D</sub></b>  | 40A             |
| <b>V<sub>DS</sub></b>   | 800V            |
| <b>R<sub>DS(on)-typ</sub></b><br>(@V <sub>GS</sub> =18V T <sub>C</sub> =25°C) | <73mΩ(Typ:53mΩ) |

**FEATURES**

- ◆High Speed Switching with Low Capacitances
- ◆High Blocking Voltage with Low RDS(on)
- ◆Easy to Parallel
- ◆Simple to Drive
- ◆RoHS Compliant

**BENEFITS**

- ◆Increased Power Density
- ◆Faster Operating Freequenc
- ◆Reduction of Heat Sink Requirements
- ◆Higher Efficiency
- ◆Reduced EMI

**APPLICATIONS**

- ◆Power Factor Correction Modules
- ◆Switch Mode Power Supplies
- ◆DC-AC Inverters
- ◆High Voltage DC/DC Converters

**MECHANICAL DATA**

- ◆Case: TO-220F/AF
- ◆Mounting Position: Any
- ◆Molded Plastic: UL Flammability Classification Rating 94V-0
- ◆Lead free in compliance with EU RoHS 2011/65/EU directive
- ◆Solder bath temperature 275°C maximum,10s per JESD 22-B106

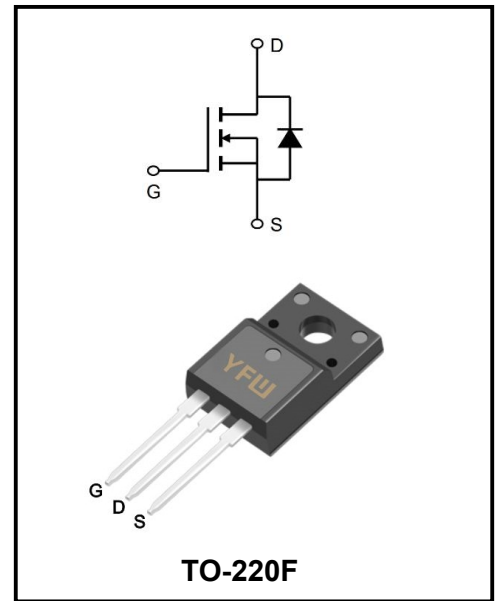

**Maximum Ratings at Tc=25°C unless otherwise specified**

| Parameter                                    | Symbol                  | Value       | Unit        |
|--|-------------------------|-------------|-------------|
| Drain-Source Voltage                         | <b>V<sub>DS</sub></b>   | 800         | <b>V</b>    |
| Gate-Source Voltage                          | <b>V<sub>GS</sub></b>   | -8/+22      | <b>V</b>    |
| Recommended Operation Value                  | <b>V<sub>GSop</sub></b> | -4/+18      | <b>V</b>    |
| Continue Drain Current T <sub>c</sub> =25°C  | <b>I<sub>D</sub></b>    | 40          | <b>A</b>    |
| Continue Drain Current T <sub>c</sub> =100°C |                         | 28          |             |
| Pulsed Drain Current                         | <b>I<sub>DM</sub></b>   | 80          | <b>A</b>    |
| Power Dissipation TC=25°C                    | <b>P<sub>D</sub></b>    | 98          | <b>W</b>    |
| Operating Temperature Range                  | <b>T<sub>J</sub></b>    | -40 to +175 | <b>°C</b>   |
| Storage Temperature Range                    | <b>T<sub>STG</sub></b>  | -40 to +175 | <b>°C</b>   |
| Thermal Resistance, Junction to Case         | <b>R<sub>θJC</sub></b>  | 1.52        | <b>°C/W</b> |
| Thermal Resistance, Junction to Ambient      | <b>R<sub>θJA</sub></b>  | 60          | <b>°C/W</b> |

**Note1:Pulse test: 300 μs pulse width, 2 % duty cycle**

**Electrical Characteristics at Tc=25°C unless otherwise specified**

| Parameter                                | Test Condition  | Symbol                    | Min | Typ  | Max  | Unit      |
|--|---|---------------------------|-----|------|------|-----------|
| Drain-Source Breakdown Voltage           | $V_{GS} = 0\text{ V}, I_D = 100\mu\text{A}$   | <b>BV<sub>DSS</sub></b>   | 800 | -    | -    | <b>V</b>  |
| Drain-Source Leakage Current             | $V_{DS} = 800\text{ V}, V_{GS} = 0\text{ V}$  | <b>I<sub>DSS</sub></b>    | -   | 1    | -    | <b>μA</b> |
| Gate Leakage Current                     | $V_{GS} = +18\text{ V}, V_{DS} = 0\text{ V}$  | <b>I<sub>GSS</sub></b>    | -   | -    | 250  | <b>nA</b> |
|  | $V_{GS} = -4\text{ V}, V_{DS} = 0\text{ V}$   |                           | -   | -    | -250 | <b>nA</b> |
| Gate-Source Threshold Voltage            | $V_{DS} = V_{GS}, I_D = 5\text{ mA}$  | <b>V<sub>GS(th)</sub></b> | 2   | 2.7  | 4    | <b>V</b>  |
| Drain-Source On-State Resistance         | $V_{GS} = 18\text{ V}, I_D = 20\text{ A}$   | <b>R<sub>DS(on)</sub></b> | -   | 53   | 73   | <b>mΩ</b> |
|  | $V_{GS} = 18\text{ V}, I_D = 20\text{ A}, T_J = 175^\circ\text{C}$  |                           | -   | 58   | -    | <b>mΩ</b> |
| Internal Gate Resistance                 | $f=1\text{MHz}$   | <b>RG</b>                 | -   | 2.1  | -    | <b>Ω</b>  |
| Input Capacitance                        | $V_{DS}=600\text{V}$<br>$V_{GS}=0\text{V}$<br>$f=1\text{MHz}$   | <b>C<sub>iss</sub></b>    | -   | 1301 | -    | <b>pF</b> |
| Output Capacitance                       |   | <b>C<sub>oss</sub></b>    | -   | 138  | -    | <b>pF</b> |
| Reverse Transfer Capacitance             |   | <b>C<sub>rss</sub></b>    | -   | 14   | -    | <b>pF</b> |
| Total Gate Charge(Note2)                 | $I_D = 20\text{ A}$<br>$V_{DD}=400\text{V}$<br>$V_{GS} = -4/+ 18\text{ V}$  | <b>Q<sub>g</sub></b>      | -   | 68   | -    | <b>nC</b> |
| Gate to Source Charge(Note2)             |   | <b>Q<sub>gs</sub></b>     | -   | 17   | -    | <b>nC</b> |
| Gate to Drain Charge(Note2)              |   | <b>Q<sub>gd</sub></b>     | -   | 22   | -    | <b>nC</b> |
| Turn-on Delay Time(Note2)                | $V_{DS} = 400\text{ V}, I_D=20\text{ A},$<br>$V_{GS} = -4/+18\text{ V},$<br>$R_G = 2.5\ \Omega$<br>$L=200\mu\text{H}$ | <b>t<sub>d(on)</sub></b>  | -   | 13   | -    | <b>ns</b> |
| Rise Time(Note2)                         |   | <b>t<sub>r</sub></b>      | -   | 20   | -    | <b>ns</b> |
| Turn-Off Delay Time(Note2)               |   | <b>t<sub>d(OFF)</sub></b> | -   | 20   | -    | <b>ns</b> |
| Fall Time(Note2)                         |   | <b>t<sub>f</sub></b>      | -   | 9    | -    | <b>ns</b> |
| Turn-on Switching Energy                 |   | <b>E<sub>on</sub></b>     | -   | 108  | -    | <b>μJ</b> |
| Turn-off Switching Energy                |   | <b>E<sub>off</sub></b>    | -   | 35   | -    | <b>μJ</b> |
| Maximun Body-Diode Continuous Current    | $V_{GS} = -4\text{ V}, T_c=25^\circ\text{C}$  | <b>I<sub>s</sub></b>      | -   | 33   | -    | <b>A</b>  |
|  | $V_{GS} = -4\text{ V}, T_c=100^\circ\text{C}$   |                           | -   | 18   | -    | <b>A</b>  |
| Maximun Body-Diode Pulsed Current(Note2) |   | <b>I<sub>SM</sub></b>     | -   | -    | 80   | <b>A</b>  |
| Drain-Source Diode Forward Voltage       | $V_{GS}=-4\text{V}, I_{SD}=10\text{A } T_j=25^\circ\text{C}$  | <b>V<sub>SD</sub></b>     | -   | 4.6  | -    | <b>V</b>  |
|  | $V_{GS}=-4\text{V}, I_{SD}=10\text{A } T_j=175^\circ\text{C}$   |                           | -   | 4    | -    | <b>V</b>  |
|  | $V_{GS}=-4\text{V}, I_{SD}=20\text{A } T_j=25^\circ\text{C}$  |                           | -   | 5.4  | -    | <b>V</b>  |
|  | $V_{GS}=-4\text{V}, I_{SD}=20\text{A } T_j=175^\circ\text{C}$   |                           | -   | 4.6  | -    | <b>V</b>  |
| Reverse Recovery Time(Note2)             | $V_{GS} = -4\text{ V}, I_{SD} = 20\text{ A}, V_R = 400\text{ V},$<br>$di/dt=989\text{A}/\mu\text{s}$                  | <b>trr</b>                | -   | 18   | -    | <b>ns</b> |
| Reverse Recovery Charge(Note2)           |   | <b>Qrr</b>                | -   | 104  | -    | <b>nC</b> |
| Peak Reverse Recovery Current            |   | <b>Irrm</b>               | -   | 10.2 | -    | <b>A</b>  |

**Note2:Pulse test: 300 us pulse width,2 % duty cycle**

**RATINGS AND CHARACTERISTIC CURVES**

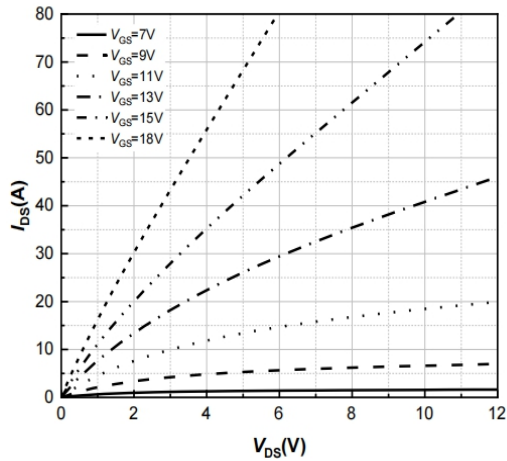

Figure 1. Output Characteristics  
 $T_j = -40^\circ\text{C}$

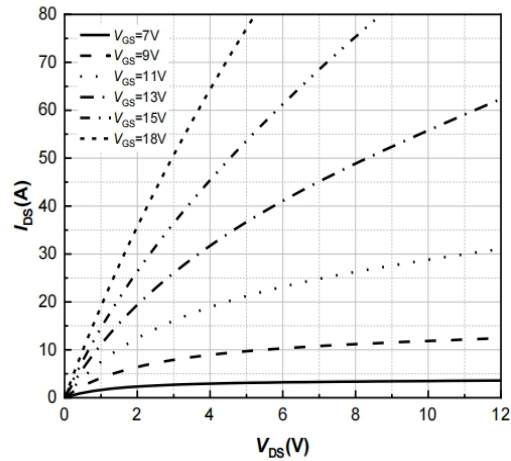

Figure 2. Output Characteristics  
 $T_j = 25^\circ\text{C}$

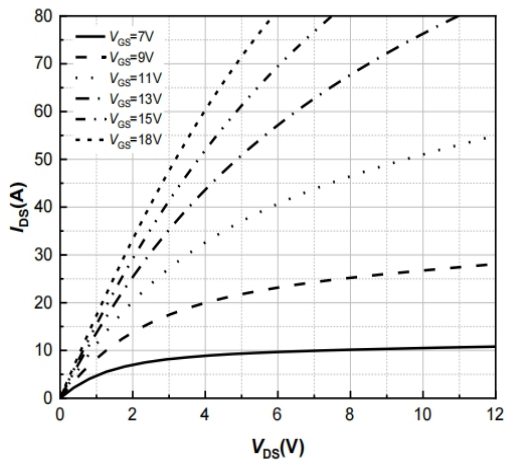

Figure 3. Output Characteristics  
 $T_j = 175^\circ\text{C}$

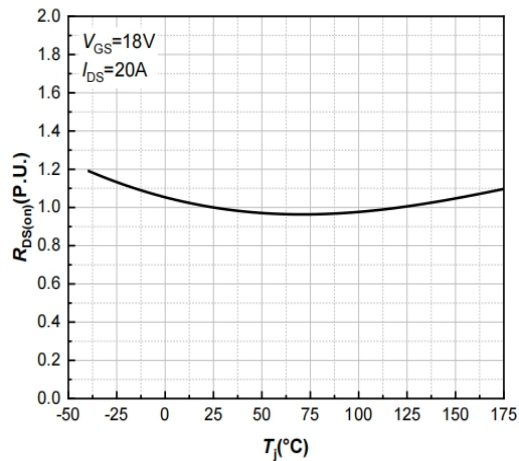

Figure 4. Normalized On-Resistance vs. Temperature

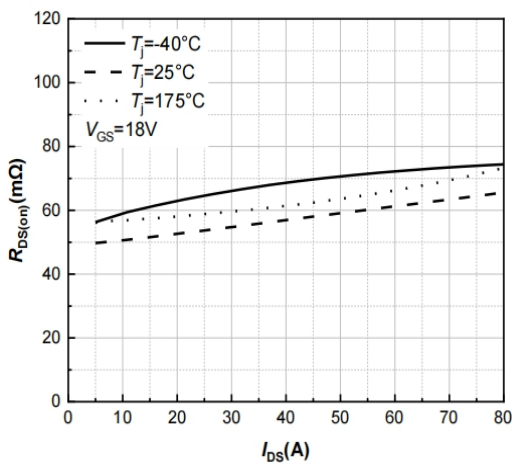

Figure 5. On-Resistance vs. Drain Current For Various Temperatures

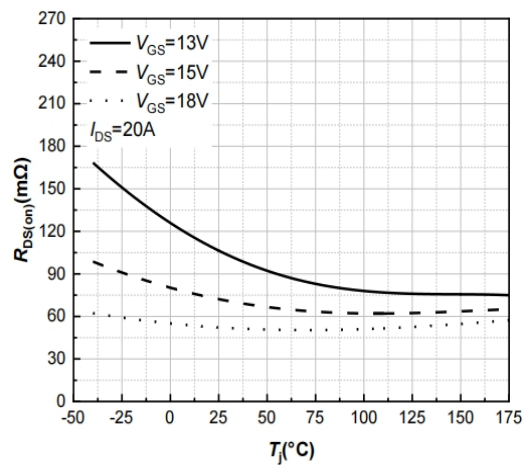

Figure 6. On-Resistance vs. Temperature For Various Gate Voltage

RATINGS AND CHARACTERISTIC CURVES

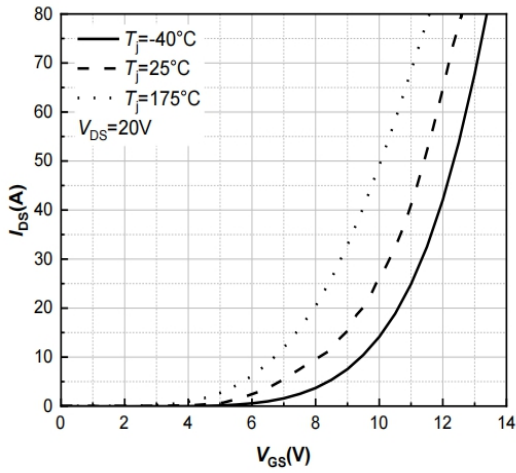

Figure 7. Transfer Characteristic for Various Junction Temperatures

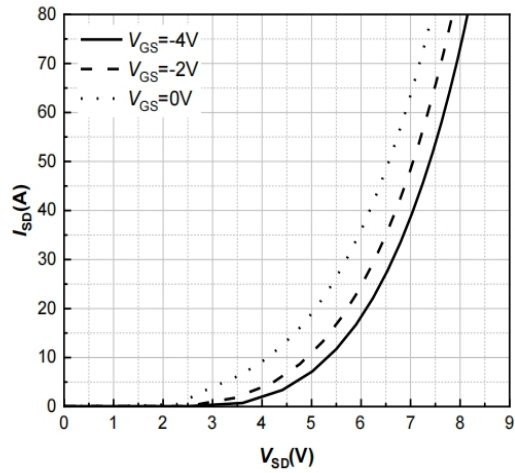

Figure 8. Body Diode Characteristic  $T_J = -40^\circ\text{C}$

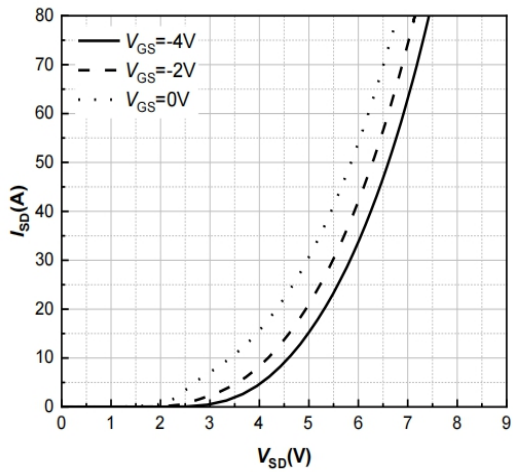

Figure 9. Body Diode Characteristic  $T_J = 25^\circ\text{C}$

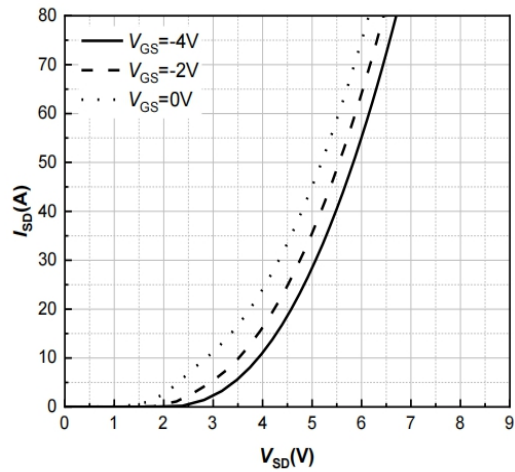

Figure 10. Body Diode Characteristic  $T_J = 175^\circ\text{C}$

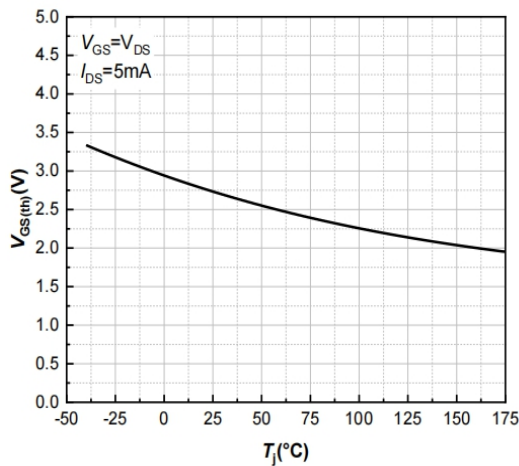

Figure 11. Threshold Voltage vs. Temperature

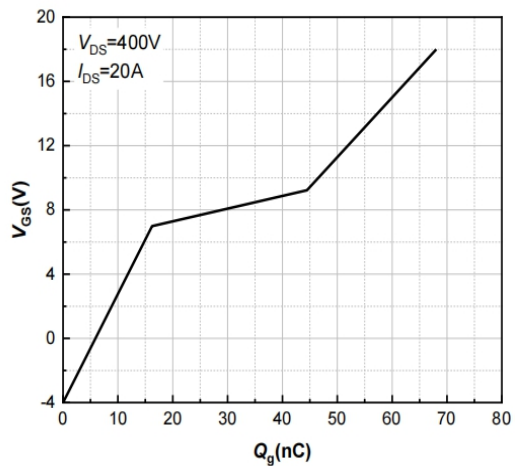

Figure 12. Gate Charge Characteristics

**RATINGS AND CHARACTERISTIC CURVES**

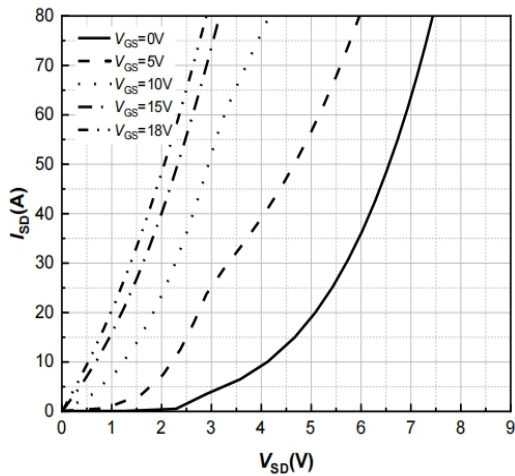

Figure 13. 3rd Quadrant Characteristic  
 $T_j = -40^\circ\text{C}$

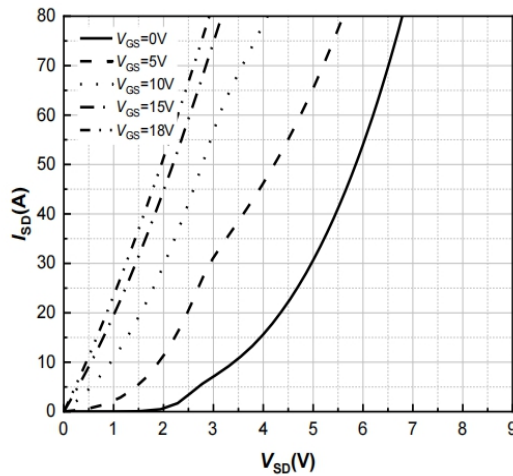

Figure 14. 3rd Quadrant Characteristic  
 $T_j = 25^\circ\text{C}$

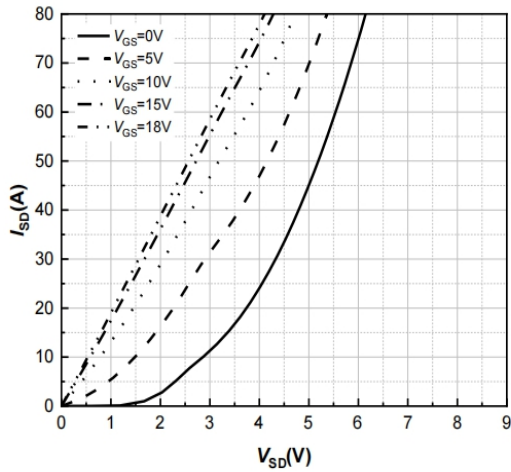

Figure 15. 3rd Quadrant Characteristic  
 $T_j = 175^\circ\text{C}$

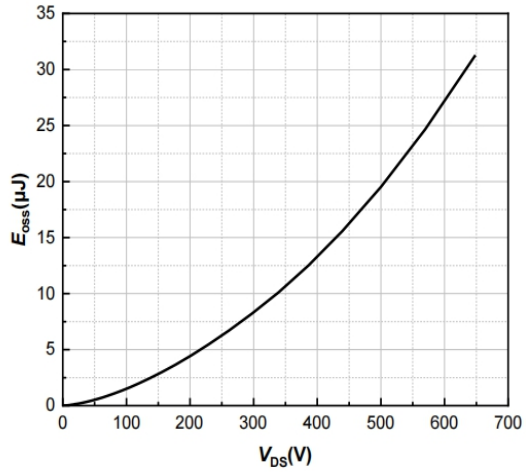

Figure 16. Output Capacitor Stored Energy

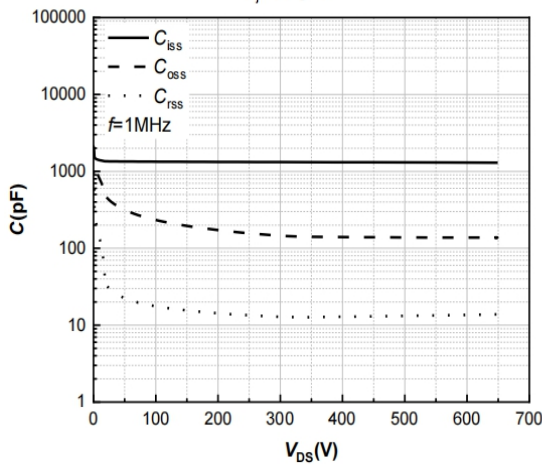

Figure 17. Capacitances vs. Drain-Source

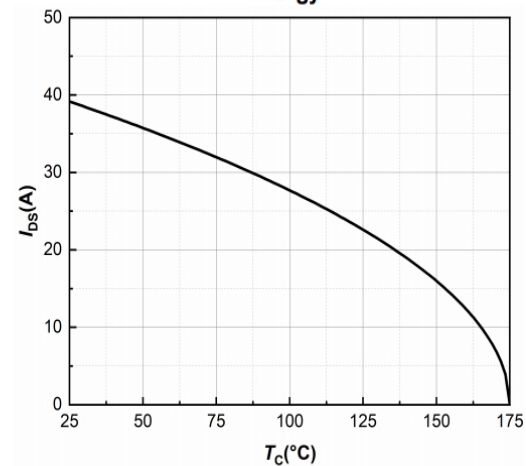

Figure 18. Continuous Drain Current Derating vs. Case Temperature

**RATINGS AND CHARACTERISTIC CURVES**

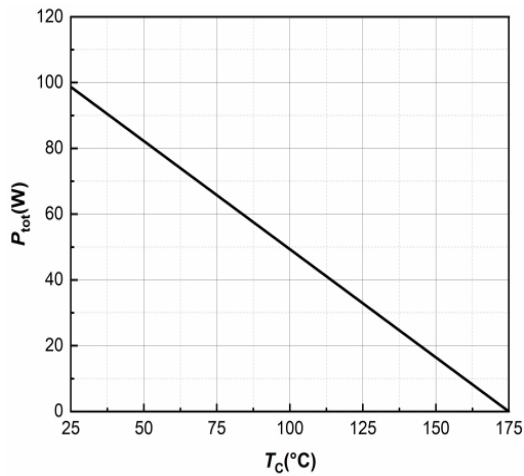

Figure 19. Maximum Power Dissipation Derating vs. Case Temperature

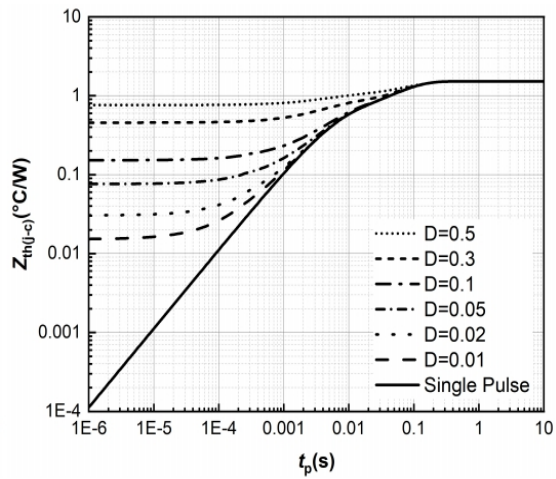

Figure 20. Transient Thermal Impedance

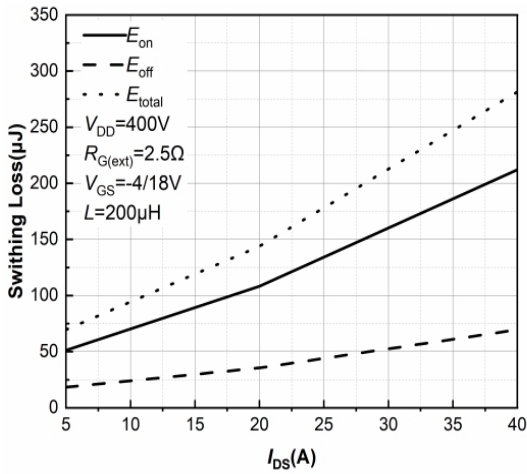

Figure 21. Clamped Inductive Switching Energy vs. Drain Current

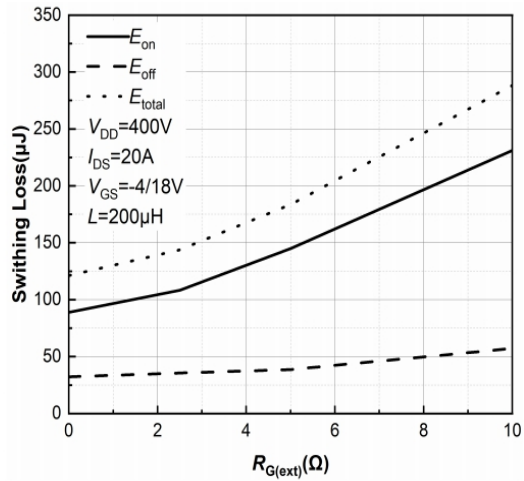

Figure 22. Clamped Inductive Switching Energy vs.  $R_{G(ext)}$

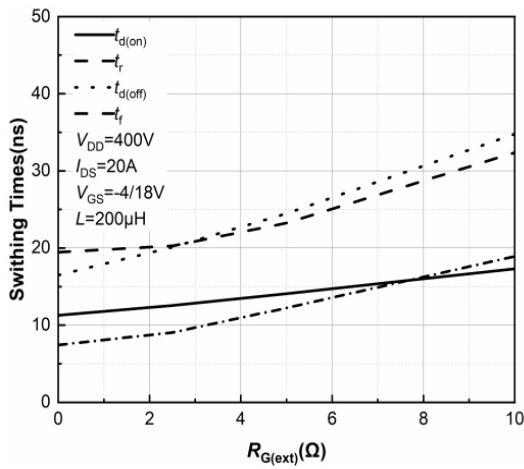

Figure 23. Switching Times vs.  $R_{G(ext)}$

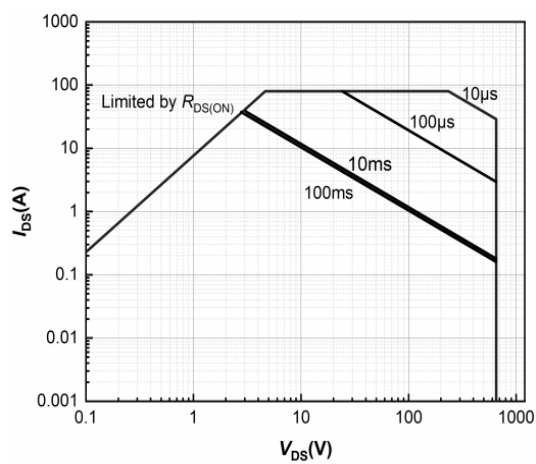
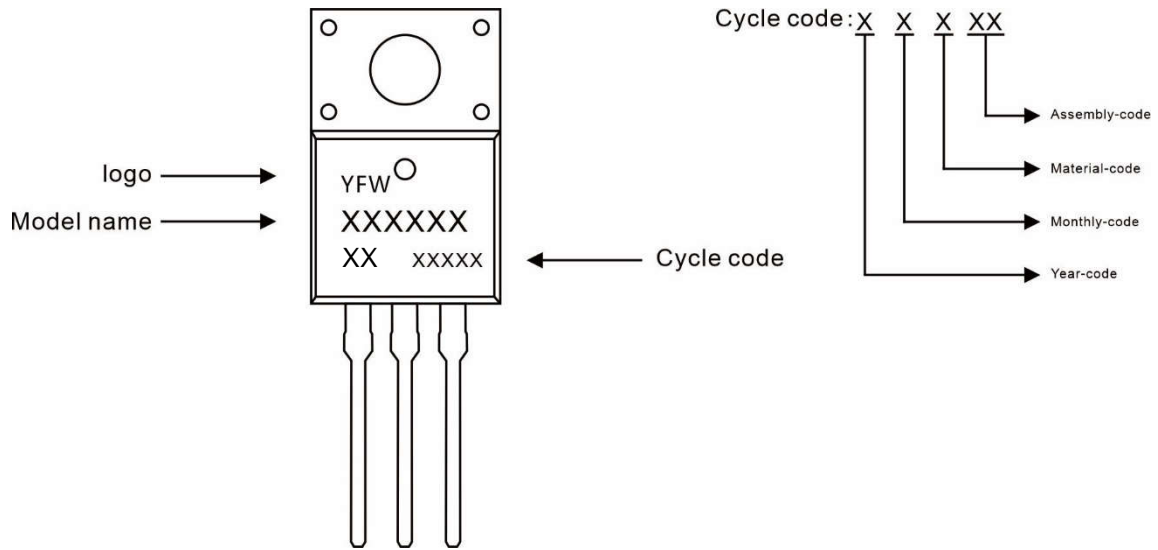

Figure 24. Safe Operating Area

**Marking Diagram**



**Ordering information**

| Model name     | Package | Unit Weight   | Base Quantity | Packing Quantity           |
|----------------|---------|---------------|---------------|----------------------------|
| YFWM305365AFG3 | TO-220F | 0.06oz(1.74g) | 50pcs/tube    | 1000PCS/Box 5000PCS/Carton |

**Package Dimensions**

**TO-220F**

| Symbol | Millimeter |       | Inches |       |
|--------|------------|-------|--------|-------|
|        | Min.       | Max.  | Min.   | Max.  |
| A      | 4.50       | 4.90  | 0.177  | 0.193 |
| A1     | 2.34       | 2.74  | 0.092  | 0.108 |
| A2     | 2.66       | 2.86  | 0.105  | 0.113 |
| b      | 0.75       | 0.85  | 0.030  | 0.033 |
| b1     | 1.24       | 1.44  | 0.049  | 0.057 |
| c      | 0.40       | 0.60  | 0.016  | 0.024 |
| D      | 10.00      | 10.32 | 0.394  | 0.406 |
| E      | 15.75      | 16.05 | 0.620  | 0.632 |
| e      | 2.44       | 2.64  | 0.096  | 0.104 |
| e1     | 4.88       | 5.28  | 0.192  | 0.208 |
| F      | 3.10       | 3.5   | 0.122  | 0.138 |
| L      | 13.50      | 13.90 | 0.531  | 0.547 |
| L1     | 2.90       | 3.30  | 0.114  | 0.130 |
| Φ      | 3.10       | 3.30  | 0.122  | 0.130 |

## Disclaimer

The information presented in this document is for reference only. GuangDong Youfeng Microelectronics Co.,Ltd. reserves the right to make changes without notice for the specification of the products displayed herein to improve reliability, function or design or otherwise. The product listed herein is designed to be used with ordinary electronic equipment or devices, and not designed to be used with equipment or devices which require high level of reliability and the malfunction of with would directly endanger human life (such as medical instruments, transportation equipment, aerospace machinery, nuclear-reactor controllers, fuel controllers and other safety devices),YFW or anyone on its behalf, assumes no responsibility or liability for any damages resulting from such improper use of sale. This publication supersedes & replaces all information previously supplied. For additional information, please visit our website <https://www.yfwdiode.com>, or consult YFW sales office for further assistance.