

Low Dropout Regulators

Description

The yfw73xx series is a set of three-terminal low power high voltage regulators implemented in CMOS technology. They allow input voltages as high as 20V. They are available with several fixed output voltages ranging from 2.1V to 9.0V. Because of the low power dissipation, yfw73xx are widely used in a variety of equipment such as audio device, video device, communication device and so on.

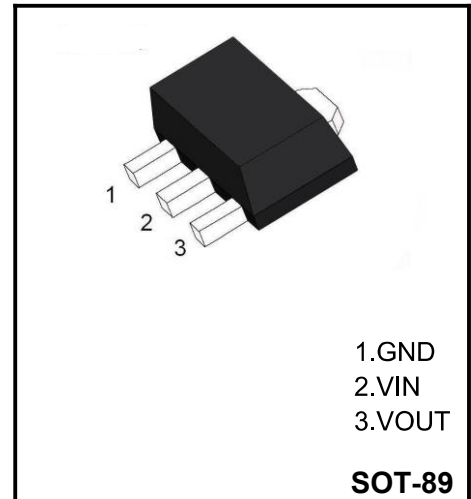

Features

- Low power consumption
- Low voltage drop
- Low temperature coefficient
- High input voltage (up to 20V)
- Quiescent current : 1.5μA
- Output voltage tolerance: ±2%
- HAF(halogen and antimony free) is acquired

Selection Table

Designator	Symbol	Description
YFW73xx	21	2.1V(output)
	23	2.3V
	25	2.5V
	28	2.8V
	30	3.0V
	33	3.3V
	36	3.6V
	40	4.0V
	44	4.4V
	50	5.0V
	90	9.0V

Absolute Maximum Ratings (Ta=25°C)

Parameter	Limit	Unit
Supply voltage	-0.3 ~ +22	V
Storage temperature range	-50 ~ +125	°C
Operating temperature range	-40 ~ 85	°C

Note: 1. Stresses beyond those listed under absolute maximum ratings may cause permanent damage to the device. These are stress ratings only, and functional operation of the device at these or any other conditions beyond those conditions is not implied. Exposure to absolute-maximum-rated conditions for extended periods may affect device reliability.

Parameter	Symbol	Value	Unit
Junction-to-Ambient Thermal Resistance	$R_{\theta JA}$	200	°C/W
Power Consumption	P_D	500	mW

Electrical Characteristics(TA = 25 °C unless otherwise specified)
YFW7321

Parameter	Symbol	Test conditions	Min.	Typ.	Max	Unit
Output voltage	V_{OUT}	$V_{IN}=V_{OUT}+2.0V$, $I_{OUT}=10mA$	2.058	2.10	2.142	V
Output current	I_{OUT}	$V_{IN}=V_{OUT}+2.0V$	300	--	--	mA
Load regulation	ΔV_{OUT}	$V_{IN}=V_{OUT}+2.0V$ $1mA \leq I_{OUT} \leq 300mA$	--	37	100	mV
Voltage drop ^{Note1}	V_{DIF}	$I_{OUT}=10mA$, $\Delta V_{OUT}=2\%$	--	45	55	mV
Quiescent Current	I_Q	No Load	--	1.5	3.0	μA
Line regulation	$\frac{\Delta V_{OUT}}{V_{OUT}} \times \Delta V_{IN}$	$V_{OUT}+1.0V \leq V_{IN} \leq 20V$, $I_{OUT}=1mA$	--	--	0.2	%/V
Input voltage	V_{IN}	--	--	--	20	V
Temperature coefficient	$\frac{\Delta V_{OUT}}{V_{OUT}} \times \Delta T_A$	$V_{IN}=V_{OUT}+2.0V$, $I_{OUT}=10mA$, $-40^\circ C \leq T_A \leq 85^\circ C$	--	100	--	ppm/°C
Short Current	I_{Short}	$V_{OUT}=0V$	--	400	--	mA

Electrical Characteristics(TA = 25 °C unless otherwise specified)
YFW7323

Parameter	Symbol	Test conditions	Min.	Typ.	Max	Unit
Output voltage	V_{OUT}	$V_{IN}=V_{OUT}+2.0V$, $I_{OUT}=10mA$	2.254	2.30	2.346	V
Output current	I_{OUT}	$V_{IN}=V_{OUT}+2.0V$	300	--	--	mA
Load regulation	ΔV_{OUT}	$V_{IN}=V_{OUT}+2.0V$ $1mA \leq I_{OUT} \leq 300mA$	--	37	100	mV
Voltage drop ^{Note1}	V_{DIF}	$I_{OUT}=10mA$, $\Delta V_{OUT}=2\%$	--	40	55	mV
Quiescent Current	I_Q	No Load	--	1.5	3.0	μA
Line regulation	$\frac{\Delta V_{OUT}}{V_{OUT}} \times \Delta V_{IN}$	$V_{OUT}+1.0V \leq V_{IN} \leq 20V$, $I_{OUT}=1mA$	--	--	0.2	%/V
Input voltage	V_{IN}	--	--	--	20	V
Temperature coefficient	$\frac{\Delta V_{OUT}}{V_{OUT}} \times \Delta T_A$	$V_{IN}=V_{OUT}+2.0V$, $I_{OUT}=10mA$, $-40^\circ C \leq T_A \leq 85^\circ C$	--	100	--	ppm/ $^\circ C$
Short Current	I_{Short}	$V_{OUT}=0V$	--	400	--	mA

Electrical Characteristics(TA = 25 °C unless otherwise specified)
YFW7325

Parameter	Symbol	Test conditions	Min.	Typ.	Max	Unit
Output voltage	V_{OUT}	$V_{IN}=V_{OUT}+2.0V$, $I_{OUT}=10mA$	2.45	2.50	2.55	V
Output current	I_{OUT}	$V_{IN}=V_{OUT}+2.0V$	300	--	--	mA
Load regulation	ΔV_{OUT}	$V_{IN}=V_{OUT}+2.0V$ $1mA \leq I_{OUT} \leq 300mA$	--	37	100	mV
Voltage drop ^{Note1}	V_{DIF}	$I_{OUT}=10mA$, $\Delta V_{OUT}=2\%$	--	35	55	mV
Quiescent Current	I_Q	No Load	--	1.5	3.0	μA
Line regulation	$\frac{\Delta V_{OUT}}{V_{OUT}} \times \Delta V_{IN}$	$V_{OUT}+1.0V \leq V_{IN} \leq 20V$, $I_{OUT}=1mA$	--	--	0.2	%/V
Input voltage	V_{IN}	--	--	--	20	V
Temperature coefficient	$\frac{\Delta V_{OUT}}{V_{OUT}} \times \Delta T_A$	$V_{IN}=V_{OUT}+2.0V$, $I_{OUT}=10mA$, $-40^\circ C \leq T_A \leq 85^\circ C$	--	100	--	ppm/ $^\circ C$
Short Current	I_{Short}	$V_{OUT}=0V$	--	400	--	mA

Electrical Characteristics(TA = 25 °C unless otherwise specified)
YFW7328

Parameter	Symbol	Test conditions	Min.	Typ.	Max	Unit
Output voltage	V_{OUT}	$V_{IN}=V_{OUT}+2.0V$, $I_{OUT}=10mA$	2.744	2.80	2.856	V
Output current	I_{OUT}	$V_{IN}=V_{OUT}+2.0V$	300	--	--	mA
Load regulation	ΔV_{OUT}	$V_{IN}=V_{OUT}+2.0V$ $1mA \leq I_{OUT} \leq 300mA$	--	37	100	mV
Voltage drop ^{Note1}	V_{DIF}	$I_{OUT}=10mA$, $\Delta V_{OUT}=2\%$	--	30	55	mV
Quiescent Current	I_Q	No Load	--	1.5	3.0	μA
Line regulation	$\frac{\Delta V_{OUT}}{V_{OUT}} \times \Delta V_{IN}$	$V_{OUT}+1.0V \leq V_{IN} \leq 20V$, $I_{OUT}=1mA$	--	--	0.2	%/V
Input voltage	V_{IN}	--	--	--	20	V
Temperature coefficient	$\frac{\Delta V_{OUT}}{V_{OUT}} \times \Delta T_A$	$V_{IN}=V_{OUT}+2.0V$, $I_{OUT}=10mA$, $-40^\circ C \leq T_A \leq 85^\circ C$	--	100	--	ppm/ $^\circ C$
Short Current	I_{Short}	$V_{OUT}=0V$	--	400	--	mA

Electrical Characteristics(TA = 25 °C unless otherwise specified)
YFW7330

Parameter	Symbol	Test conditions	Min.	Typ.	Max	Unit
Output voltage	V_{OUT}	$V_{IN}=V_{OUT}+2.0V$, $I_{OUT}=10mA$	2.94	3.0	3.06	V
Output current	I_{OUT}	$V_{IN}=V_{OUT}+2.0V$	300	--	--	mA
Load regulation	ΔV_{OUT}	$V_{IN}=V_{OUT}+2.0V$ $1mA \leq I_{OUT} \leq 300mA$	--	37	100	mV
Voltage drop ^{Note1}	V_{DIF}	$I_{OUT}=100mA$, $\Delta V_{OUT}=2\%$	--	210	300	mV
Quiescent Current	I_Q	No Load	--	1.5	3.0	μA
Line regulation	$\frac{\Delta V_{OUT}}{V_{OUT}} \times \Delta V_{IN}$	$V_{OUT}+1.0V \leq V_{IN} \leq 20V$, $I_{OUT}=1mA$	--	--	0.2	%/V
Input voltage	V_{IN}	--	--	--	20	V
Temperature coefficient	$\frac{\Delta V_{OUT}}{V_{OUT}} \times \Delta T_A$	$V_{IN}=V_{OUT}+2.0V$, $I_{OUT}=10mA$, $-40^\circ C \leq T_A \leq 85^\circ C$	--	100	--	ppm/ $^\circ C$
Short Current	I_{Short}	$V_{OUT}=0V$	--	400	--	mA

Electrical Characteristics(TA = 25 °C unless otherwise specified)
YFW7333

Parameter	Symbol	Test conditions	Min.	Typ.	Max	Unit
Output voltage	V _{OUT}	V _{IN} =V _{OUT} +2.0V, I _{OUT} =10mA	3.234	3.30	3.366	V
Output current	I _{OUT}	V _{IN} =V _{OUT} +2.0V	300	--	--	mA
Load regulation	ΔV _{OUT}	V _{IN} =V _{OUT} +2.0V 1mA≤I _{OUT} ≤300mA	--	37	100	mV
Voltage drop ^{Note1}	V _{DIF}	I _{OUT} =100mA, ΔV _{OUT} =2%	--	195	300	mV
Quiescent Current	I _Q	No Load	--	1.5	3.0	μA
Line regulation	$\frac{\Delta V_{OUT}}{V_{OUT}} \times \Delta V_{IN}$	V _{OUT} +1.0V≤V _{IN} ≤20V, I _{OUT} =1mA	--	--	0.2	%/V
Input voltage	V _{IN}	--	--	--	20	V
Temperature coefficient	$\frac{\Delta V_{OUT}}{V_{OUT}} \times \Delta T_A$	V _{IN} =V _{OUT} +2.0V, I _{OUT} =10mA, -40°C≤T _A ≤85°C	--	100	--	ppm/°C
Short Current	I _{Short}	V _{OUT} =0V	--	400	--	mA

Electrical Characteristics(TA = 25 °C unless otherwise specified)
YFW7336

Parameter	Symbol	Test conditions	Min.	Typ.	Max	Unit
Output voltage	V _{OUT}	V _{IN} =V _{OUT} +2.0V, I _{OUT} =10mA	3.528	3.60	3.672	V
Output current	I _{OUT}	V _{IN} =V _{OUT} +2.0V	300	--	--	mA
Load regulation	ΔV _{OUT}	V _{IN} =V _{OUT} +2.0V 1mA≤I _{OUT} ≤300mA	--	37	100	mV
Voltage drop ^{Note1}	V _{DIF}	I _{OUT} =100mA, ΔV _{OUT} =2%	--	180	300	mV
Quiescent Current	I _Q	No Load	--	1.5	3.0	μA
Line regulation	$\frac{\Delta V_{OUT}}{V_{OUT}} \times \Delta V_{IN}$	V _{OUT} +1.0V≤V _{IN} ≤20V, I _{OUT} =1mA	--	--	0.2	%/V
Input voltage	V _{IN}	--	--	--	20	V
Temperature coefficient	$\frac{\Delta V_{OUT}}{V_{OUT}} \times \Delta T_A$	V _{IN} =V _{OUT} +2.0V, I _{OUT} =10mA, -40°C≤T _A ≤85°C	--	100	--	ppm/°C
Short Current	I _{Short}	V _{OUT} =0V	--	400	--	mA

Electrical Characteristics(TA = 25 °C unless otherwise specified)
YFW7340

Parameter	Symbol	Test conditions	Min.	Typ.	Max	Unit
Output voltage	V_{OUT}	$V_{IN}=V_{OUT}+2.0V, I_{OUT}=10mA$	3.92	4.0	4.08	V
Output current	I_{OUT}	$V_{IN}=V_{OUT}+2.0V$	300	--	--	mA
Load regulation	ΔV_{OUT}	$V_{IN}=V_{OUT}+2.0V$ $1mA \leq I_{OUT} \leq 300mA$	--	37	100	mV
Voltage drop ^{Note1}	V_{DIF}	$I_{OUT}=100mA, \Delta V_{OUT}=2\%$	--	170	300	mV
Quiescent Current	I_Q	No Load	--	1.5	3.0	μA
Line regulation	$\frac{\Delta V_{OUT}}{V_{OUT}} \times \Delta V_{IN}$	$V_{OUT}+1.0V \leq V_{IN} \leq 20V, I_{OUT}=1mA$	--	--	0.2	%/V
Input voltage	V_{IN}	--	--	--	20	V
Temperature coefficient	$\frac{\Delta V_{OUT}}{V_{OUT}} \times \Delta T_A$	$V_{IN}=V_{OUT}+2.0V, I_{OUT}=10mA,$ $-40^\circ C \leq T_A \leq 85^\circ C$	--	100	--	ppm/ $^\circ C$
Short Current	I_{Short}	$V_{OUT}=0V$	--	400	--	mA

Electrical Characteristics(TA = 25 °C unless otherwise specified)
YFW7344

Parameter	Symbol	Test conditions	Min.	Typ.	Max	Unit
Output voltage	V_{OUT}	$V_{IN}=V_{OUT}+2.0V, I_{OUT}=10mA$	4.312	4.4	4.488	V
Output current	I_{OUT}	$V_{IN}=V_{OUT}+2.0V$	300	--	--	mA
Load regulation	ΔV_{OUT}	$V_{IN}=V_{OUT}+2.0V$ $1mA \leq I_{OUT} \leq 300mA$	--	37	100	mV
Voltage drop ^{Note1}	V_{DIF}	$I_{OUT}=100mA, \Delta V_{OUT}=2\%$	--	160	300	mV
Quiescent Current	I_Q	No Load	--	1.5	3.0	μA
Line regulation	$\frac{\Delta V_{OUT}}{V_{OUT}} \times \Delta V_{IN}$	$V_{OUT}+1.0V \leq V_{IN} \leq 20V, I_{OUT}=1mA$	--	--	0.2	%/V
Input voltage	V_{IN}	--	--	--	20	V
Temperature coefficient	$\frac{\Delta V_{OUT}}{V_{OUT}} \times \Delta T_A$	$V_{IN}=V_{OUT}+2.0V, I_{OUT}=10mA,$ $-40^\circ C \leq T_A \leq 85^\circ C$	--	100	--	ppm/ $^\circ C$
Short Current	I_{Short}	$V_{OUT}=0V$	--	400	--	mA

Electrical Characteristics(TA = 25 °C unless otherwise specified)
YFW7350

Parameter	Symbol	Test conditions	Min.	Typ.	Max	Unit
Output voltage	V_{OUT}	$V_{IN}=V_{OUT}+2.0V$, $I_{OUT}=10mA$	4.90	5.0	5.10	V
Output current	I_{OUT}	$V_{IN}=V_{OUT}+2.0V$	300	--	--	mA
Load regulation	ΔV_{OUT}	$V_{IN}=V_{OUT}+2.0V$ $1mA \leq I_{OUT} \leq 300mA$	--	37	100	mV
Voltage drop ^{Note1}	V_{DIF}	$I_{OUT}=100mA$, $\Delta V_{OUT}=2\%$	--	150	300	mV
Quiescent Current	I_Q	No Load	--	1.5	3.0	μA
Line regulation	$\frac{\Delta V_{OUT}}{V_{OUT}} \times \Delta V_{IN}$	$V_{OUT}+1.0V \leq V_{IN} \leq 20V$, $I_{OUT}=1mA$	--	--	0.2	%/V
Input voltage	V_{IN}	--	--	--	20	V
Temperature coefficient	$\frac{\Delta V_{OUT}}{V_{OUT}} \times \Delta T_A$	$V_{IN}=V_{OUT}+2.0V$, $I_{OUT}=10mA$, $-40^\circ C \leq T_A \leq 85^\circ C$	--	100	--	ppm/ $^\circ C$
Short Current	I_{Short}	$V_{OUT}=0V$	--	400	--	mA

Electrical Characteristics(TA = 25 °C unless otherwise specified)
YFW7390

Parameter	Symbol	Test conditions	Min.	Typ.	Max	Unit
Output voltage	V_{OUT}	$V_{IN}=V_{OUT}+2.0V$, $I_{OUT}=10mA$	8.82	9.0	9.18	V
Output current	I_{OUT}	$V_{IN}=V_{OUT}+2.0V$	300	--	--	mA
Load regulation	ΔV_{OUT}	$V_{IN}=V_{OUT}+2.0V$ $1mA \leq I_{OUT} \leq 300mA$	--	37	100	mV
Voltage drop ^{Note1}	V_{DIF}	$I_{OUT}=100mA$, $\Delta V_{OUT}=2\%$	--	130	300	mV
Quiescent Current	I_Q	No Load	--	1.5	3.0	μA
Line regulation	$\frac{\Delta V_{OUT}}{V_{OUT}} \times \Delta V_{IN}$	$V_{OUT}+1.0V \leq V_{IN} \leq 20V$, $I_{OUT}=1mA$	--	--	0.2	%/V
Input voltage	V_{IN}	--	--	--	20	V
Temperature coefficient	$\frac{\Delta V_{OUT}}{V_{OUT}} \times \Delta T_A$	$V_{IN}=V_{OUT}+2.0V$, $I_{OUT}=10mA$, $-40^\circ C \leq T_A \leq 85^\circ C$	--	100	--	ppm/ $^\circ C$
Short Current	I_{Short}	$V_{OUT}=0V$	--	400	--	mA

Applications Circuit

Basic circuits

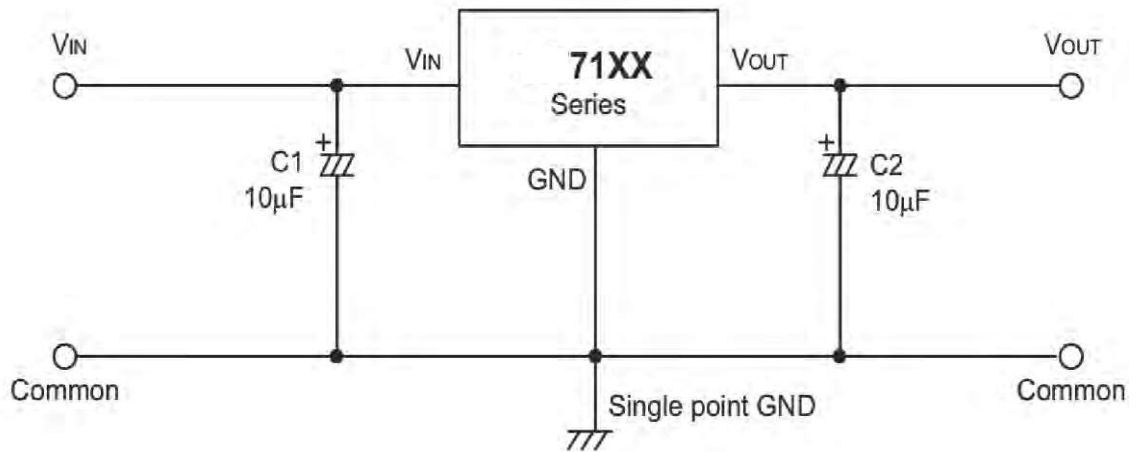

Ordering information

Package	Packing Description	Base Quantity	Packing Quantity
SOT-89	Tape/Reel,7"reel	1000pcs/Reel	6000PCS/Box 30000PCS/Carton

Package Dimensions

SOT-89

Dim	Millimeter		Inches	
	Min.	Max.	Min.	Max.
A	1.40	1.60	0.055	0.063
b	0.32	0.52	0.013	0.020
b1	0.38	0.58	0.015	0.023
c	0.35	0.45	0.014	0.018
D	4.40	4.60	0.173	0.181
D1	1.45	1.65	0.057	0.065
D2	1.70	1.80	0.067	0.071
E	2.30	2.60	0.091	0.102
E1	3.95	4.25	0.156	0.167
E2	1.80	2.00	0.071	0.079
e	1.40	1.60	0.055	0.063
e1	2.80	3.20	0.110	0.126
L	0.90	1.20	0.035	0.047

The recommended mounting pad size

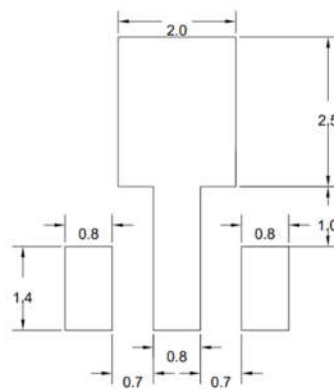

UNIT:MM

Disclaimer

The information presented in this document is for reference only. GuangDong Youfeng Microelectronics Co.,Ltd. reserves the right to make changes without notice for the specification of the products displayed herein to improve reliability, function or design or otherwise. The product listed herein is designed to be used with ordinary electronic equipment or devices, and not designed to be used with equipment or devices which require high level of reliability and the malfunction of with would directly endanger human life (such as medical instruments, transportation equipment, aerospace machinery, nuclear-reactor controllers, fuel controllers and other safety devices),YFW or anyone on its behalf, assumes no responsibility or liability for any damages resulting from such improper use of sale. This publication supersedes & replaces all information previously supplied. For additional information, please visit our website <https://www.yfwdiode.com>, or consult YFW sales office for further assistance.